

Busway Construction

Bus Bars

A better understanding of what busway is can be gained by examining its construction. A typical Siemens Sentron™ busway section has three or four formed aluminum or copper bars that function as electrical conductors. Aluminum busway can be supplied in ampacities up to 4000 amperes. Copper busway can be supplied in ampacities up to 5000 amperes.

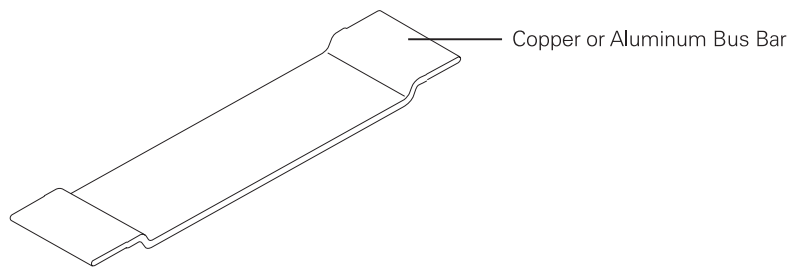

Bus bars manufactured for use in feeder busway differ from those manufactured for use in plug-in busway. Plug-in busway will have a tab or some other form of connecting a plug-in device such as a disconnect.

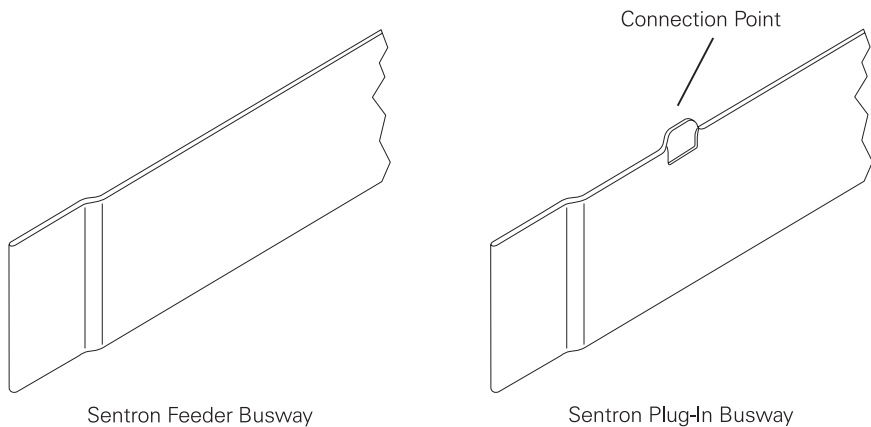

Each bus bar is referred to as a phase. Bus bars of Sentron busway are separated electrically with epoxy insulation.

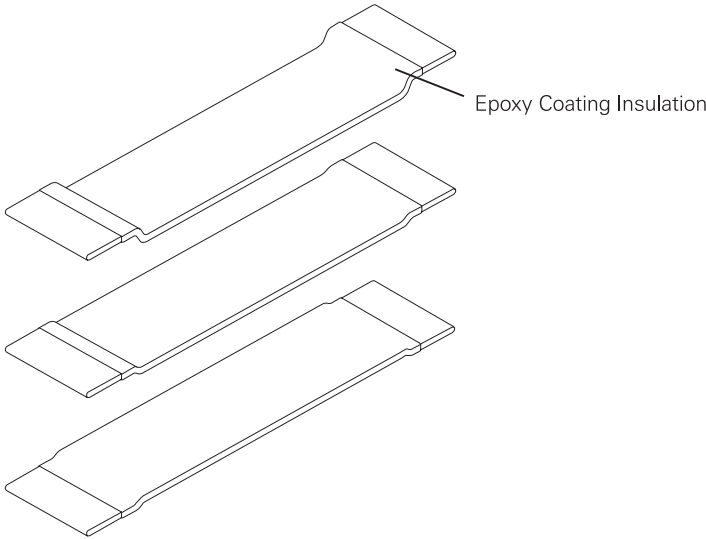

Enclosure

Glass wrap tape is wrapped around the Sentron bus bars to provide additionally protection and hold the bars together. The bus bars are then installed in an enclosure. The enclosure provides protection and support.

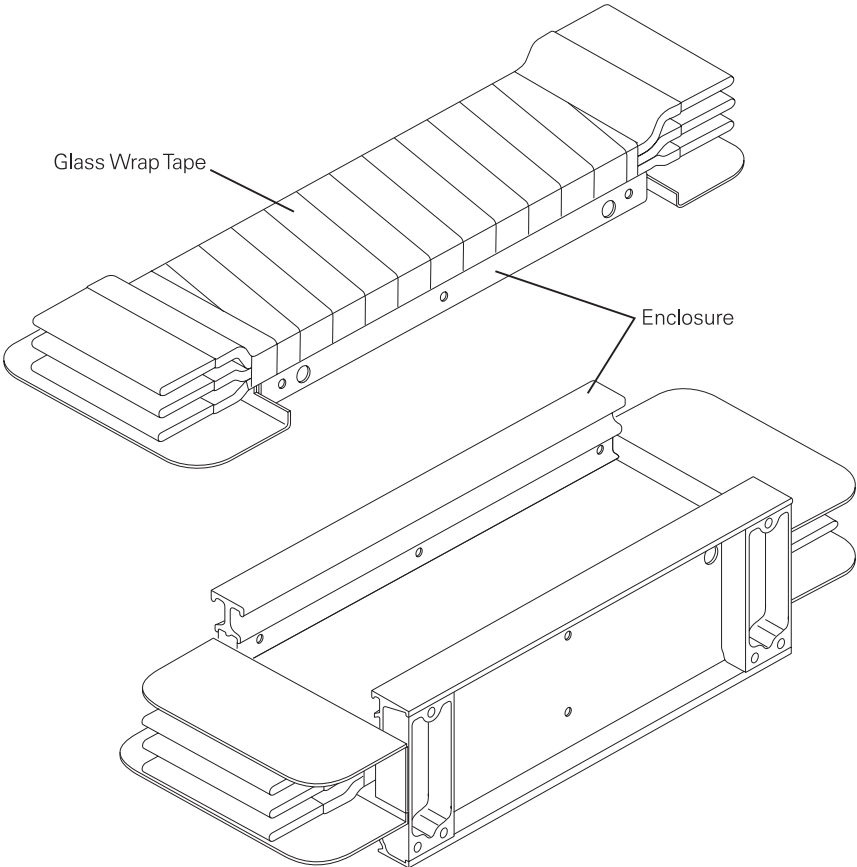

Bars per Pole

Sentron busway uses one bar per pole on busway rated up to 2000 amperes aluminum and 2500 amperes copper.

One Bar Per Pole

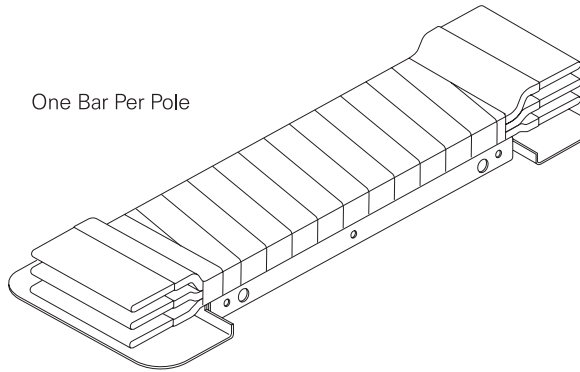

Ampere Rating	
Aluminum	Copper
800	800
1000	1000
1200	1200
1350	1350
1600	1600
2000	2000
	2500

Sentron busway uses two bars per pole on busway rated from 2500 to 4000 amperes aluminum and 3000 to 5000 amperes copper.

Two Bars Per Pole

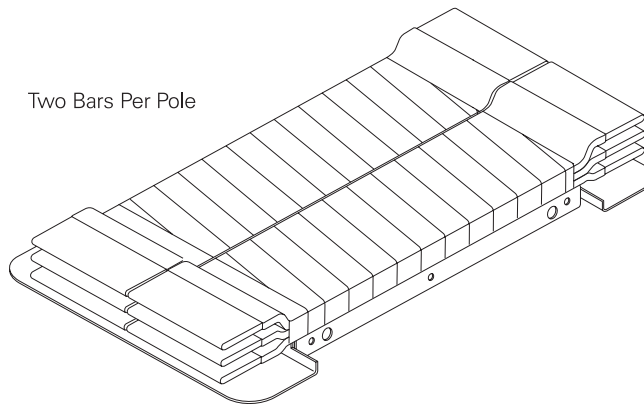

Ampere Rating	
Aluminum	Copper
2500	3000
3000	4000
4000	5000

NEMA Phase Arrangement

Bus bars are required to have phases in sequence so that an installer can have the same fixed phase arrangement in each termination point. This is established by NEMA (National Electrical Manufacturers Association). The following diagram illustrates accepted NEMA phase arrangements.

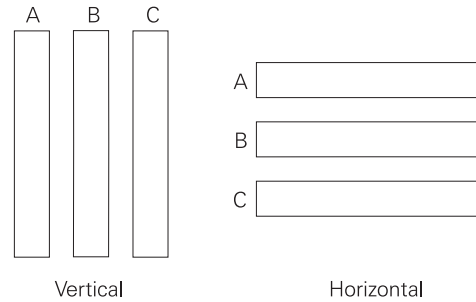

The following illustration shows the proper phase arrangement of bus bars in Sentron busway.

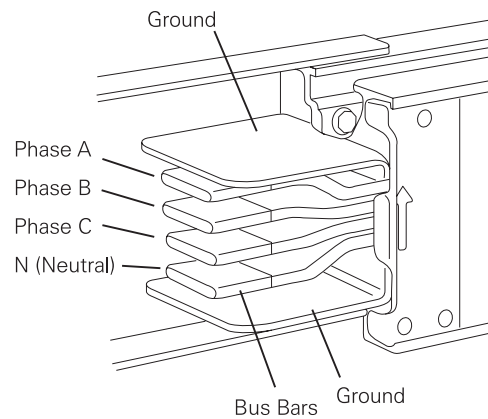

Number of Bus Bars

The number of bars depends on the number of phases on the power supply and whether or not a neutral or ground is used.

3 Phase, 3 Wire

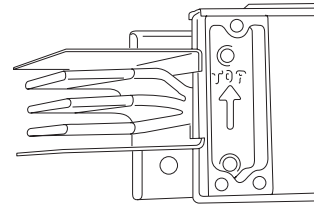

3 Phase, 4 Wire (Neutral)

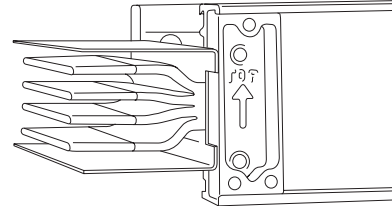

200% Neutral

Siemens Sentron busway is available with a 200% neutral within the bus bar housing. Certain loads on the distribution system can cause non-sinusoidal current referred to as harmonics. These harmonics cause circulating currents which increase the heat in the system and shorten component life. The 200% neutral capacity minimizes overheating, thus prolonging the life of power distribution equipment.

3 Phase, 4 Wire, 100% Neutral

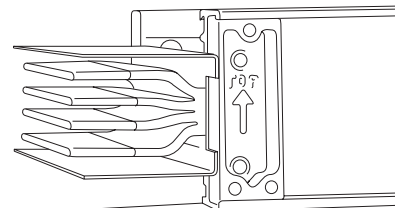

3 Phase, 4 Wire, 200% Neutral

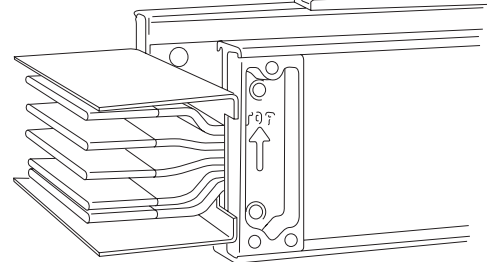

Ground

The *National Electrical Code*® requires the metal enclosure of any busway run to be grounded back at the service entrance equipment. Sentron busway has several options to meet this requirement. The busway housing is an integral ground. Under more severe industrial applications a heavier ground may be required. The following cross section drawing of Sentron busway shows a bus bar a 50% internal ground has been added. This means that the ground is rated at 50% of the ampacity of the phase bus bars.

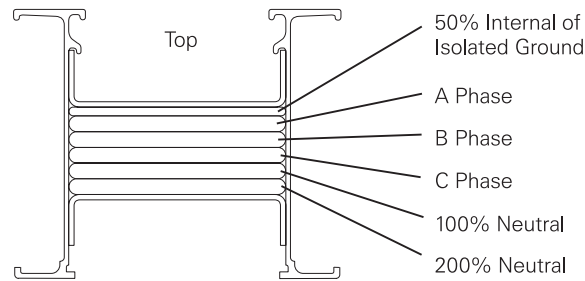

Busway Lengths

The standard length of a plug-in busway section is 10' (3048 mm). Sentron busway is also available in 4' (1219 mm), 6' (1829 mm), 8' (2438 mm), and 8' (2438 mm) lengths.

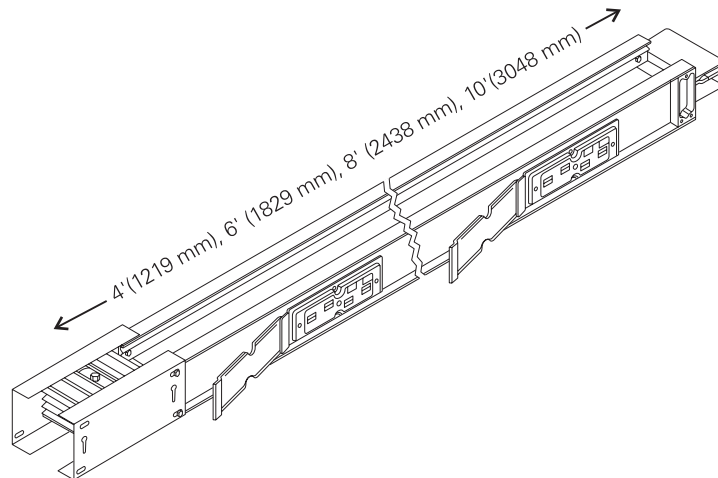

Plug-in outlets on Sentron plug-in busway are located on 2' (610 mm) centers on both sides of the busway.

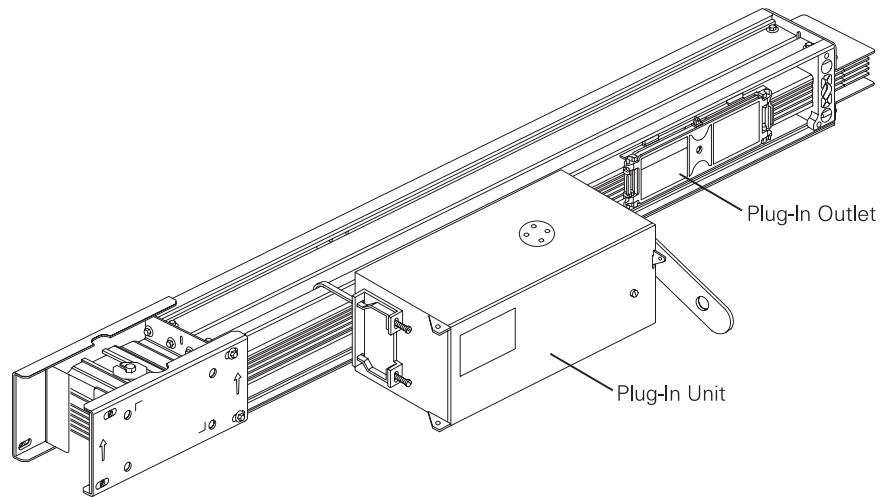

Sentron Plug-In Outlets

The Sentron plug-in outlet features a molded guard which prevents incidental finger contact with live conductors. This meets IEC, IP 2X requirements for preventing a 0.472" (12 mm) probe from entering. This is referred to as finger safe.

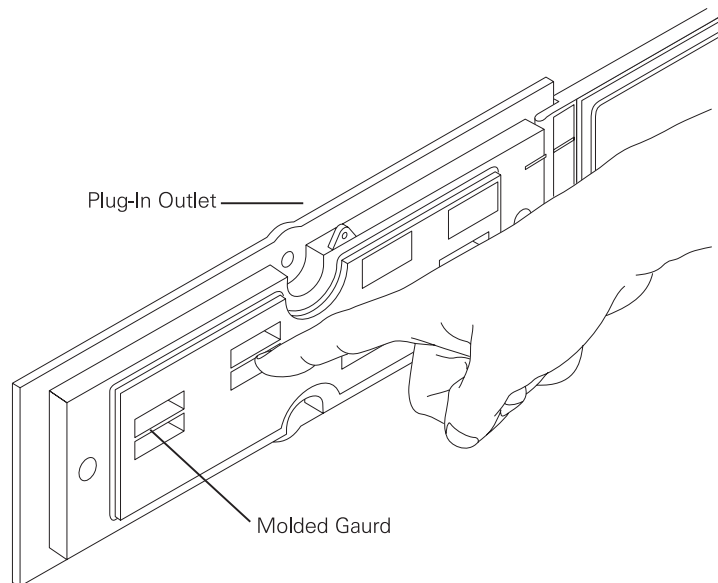

Feeder Busway Lengths

In addition to the 4' (1219 mm), 6' (1829 mm), 8' (2438 mm), and standard 10' (3048 mm) lengths, Sentron feeder busway sections are available in 0.125" (3.2 mm) increments from 1' 4.5" (419 mm) to 10' (3048 mm). Feeder busway does not have any plug-in outlets.

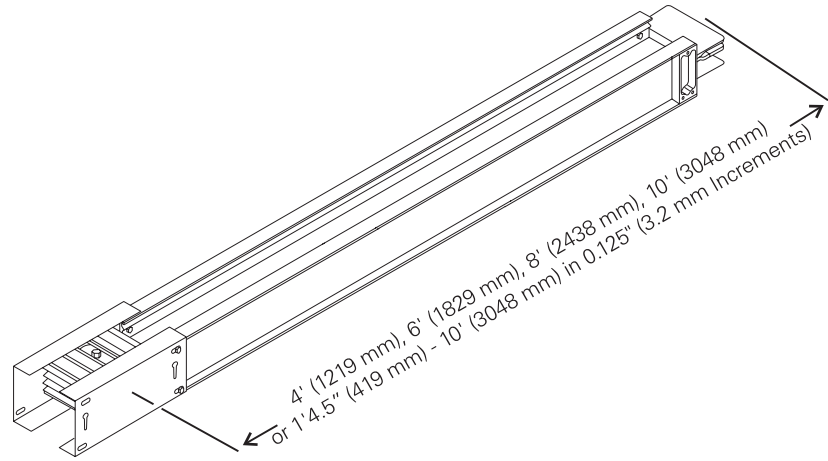

Review 3

1. In the Sentron busway, aluminum bus bars are available with ampacities up to _____ amperes and copper bus bars are available with ampacities up to _____ amperes.
2. Identify the type of busway each of the bus bars represent in the following illustration.

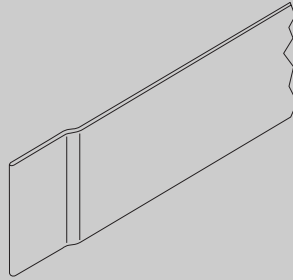

a. _____

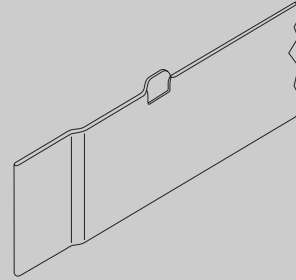

b. _____

3. Plug-in busway is available in _____ , _____ , _____ , and 10 foot lengths.
4. Plug-in outlets are located on _____ foot centers.
5. Sentron feeder busway sections are available in _____ inch increments from _____ to _____ feet.

Busway System Components

There are a number of components that make up a busway system. The various system components illustrated in this section, unless otherwise noted, will be the Siemens Sentron™ series. For more information on any component consult the *Sentron Busway System Selection and Application Guide*. It should also be noted that certain components available on one type busway system may not be available on another type busway system.

Although components used in various busway systems perform the same or similar functions, they can't be interchanged from one busway system to another. There are a number of reasons for this. Systems are tested and rated as a complete unit. Ratings and system integrity could not be guaranteed when components are interchanged between systems. Additionally, components from one system may not physically fit or connect to components of another system. Sections of Siemens Sentron busway, for example are clamped together with a joint stack. Siemens BD™ busway is bolted together.

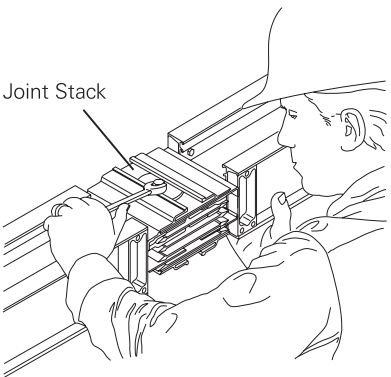

Sentron Busway

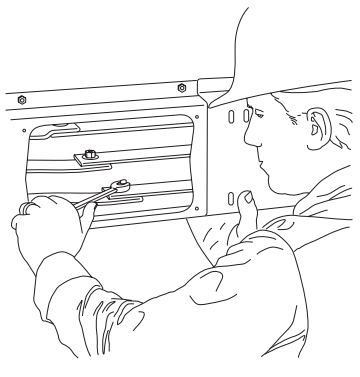

BD Busway

Joint Stack

The Siemens Sentron busway system, uses a single-bolt joint stack to connect busway sections. The bus bars from two busway sections are slid into a joint stack.

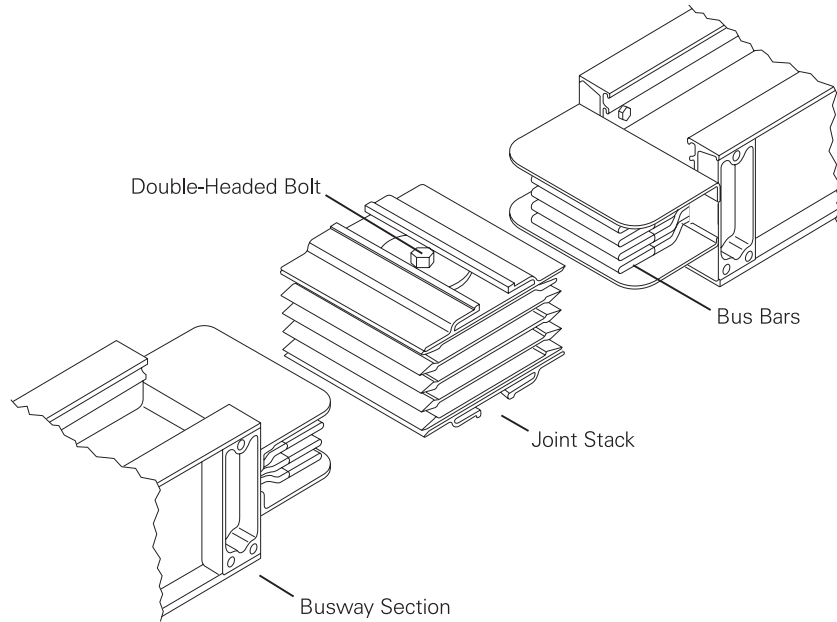

The assembly is clamped solidly together with the single bolt located on the joint stack. Sentron busway sections and components are supplied with required joint stacks.

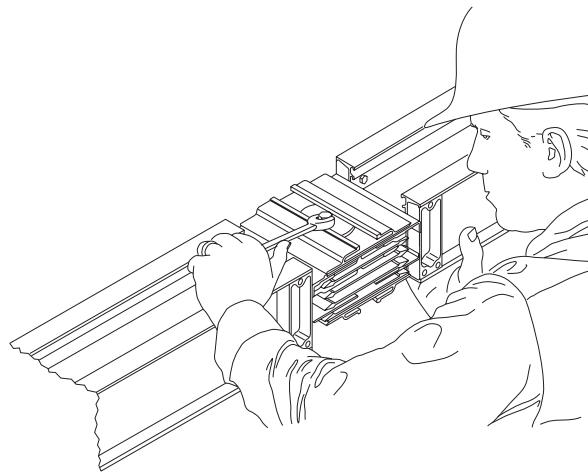

The single-joint bolt is a double-headed break-off bolt. The outer head is 5/8" and the bottom head is 3/4". The double-headed bolt is tightened until the 5/8" outer head twists off (approximately 55 ft. lbs.). This eliminates the need for torque wrenches during initial installation. The bottom 3/4" head is permanent and is used for future joint maintenance. Each joint is adjustable by $\pm 5/8$ ".

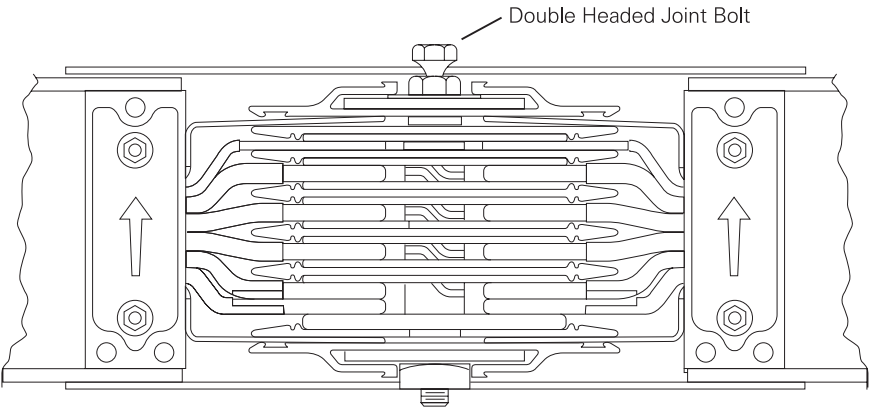

Elbows

Elbows, offsets, and tees allow for turns and height changes in the busway system to be made in any direction. An elbow can turn the busway system right or left, up or down. Elbows are supplied with a joint stack and covers.

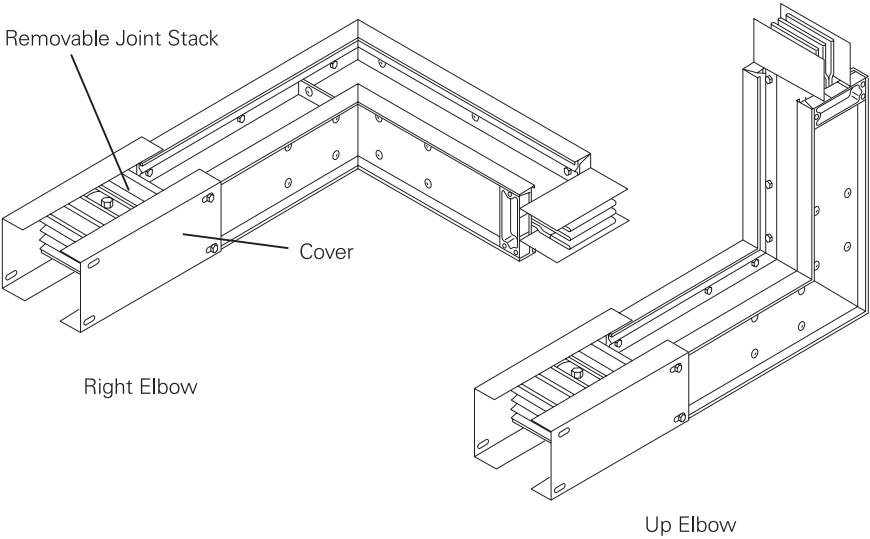

Combination Elbows

Combination elbows can turn the busway system up or down, and right or left.

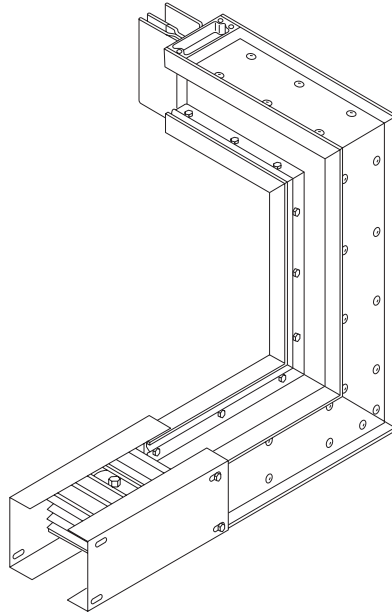

Up, Left Combination Elbow

Tees

Tees are used to start a new section of busway in a different direction. Tees can start a new section to the right, to the left, up, or down. Tees are supplied with two joint stacks.

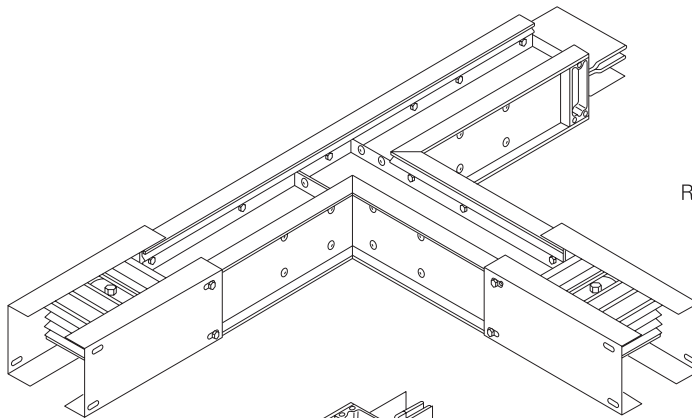

Right Tee

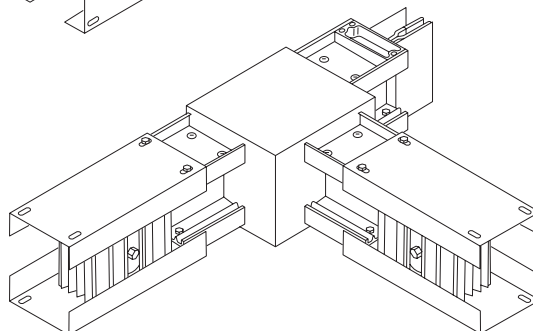

Down Tee

Crosses

A cross allows a busway run to expand in four directions.

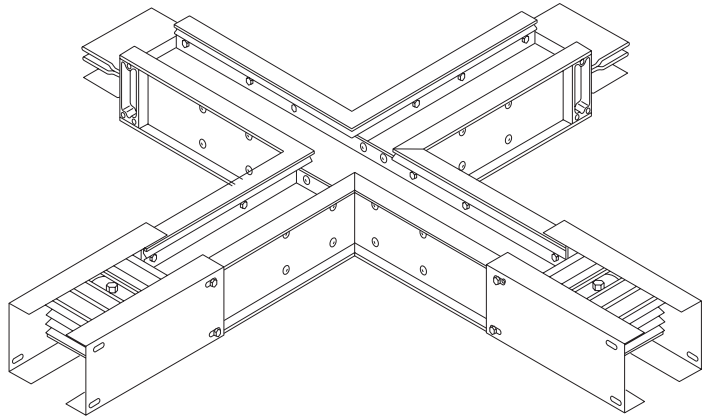

Offsets

Offsets allow the busway system to continue in the same direction. Offsets can move the busway system to the right, to the left, up, or down. Offsets are supplied with a joint stack.

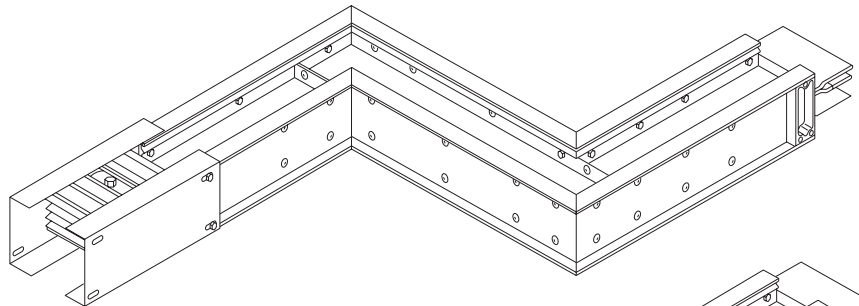

Right Offset

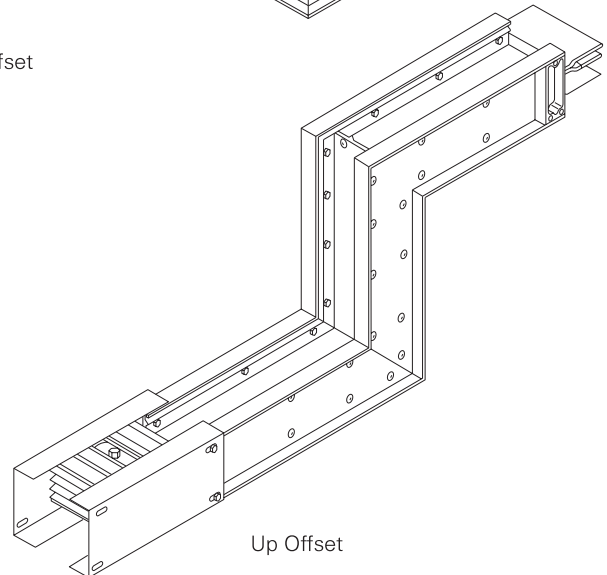

Up Offset

Cable Tap Boxes

Tap boxes are used to connect electrical cable to the busway distribution system. End cable tap boxes can be installed at either end of the busway system. They can be used on feeder or plug-in busway.

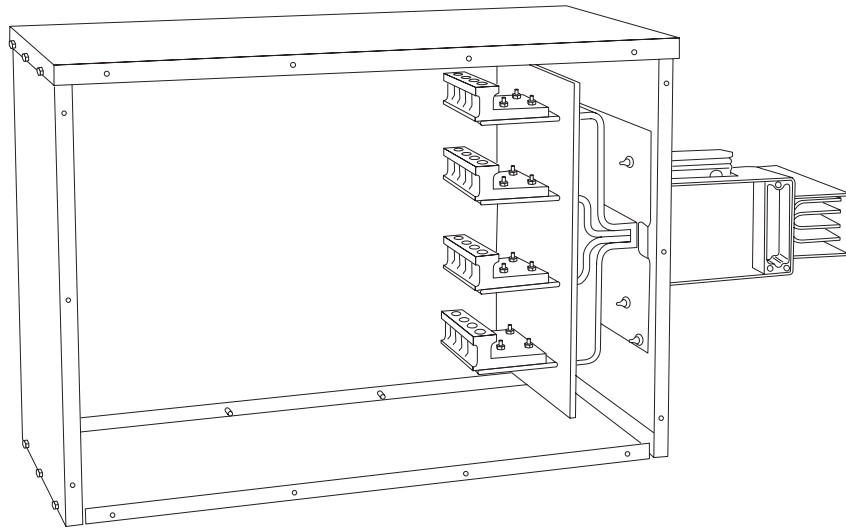

End Cable Tap Box

Center, or plug-in, cable tap boxes can be installed along the length of a busway system. Plug-in cable tap boxes can only be used on plug-in busway.

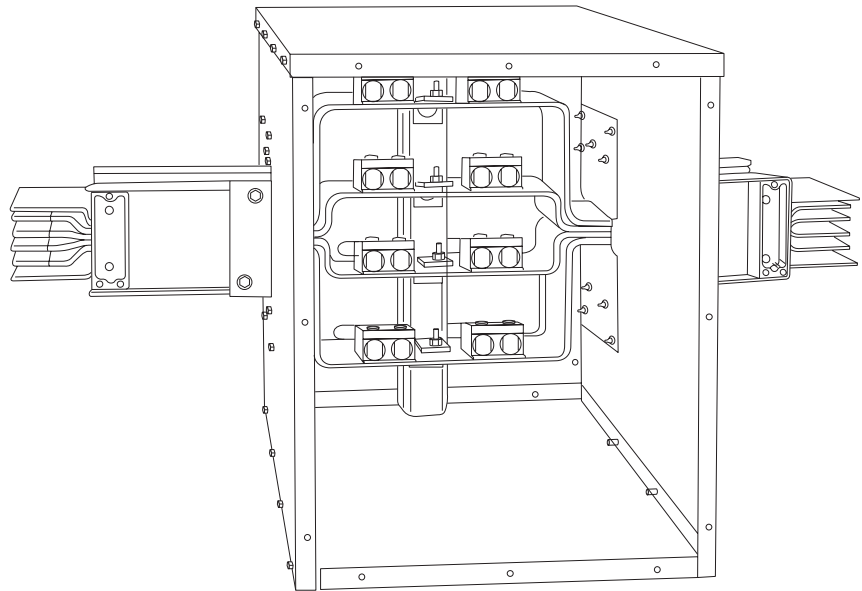

Center Cable Tap Box

Stubs

Sentron busway standard stubs can be used to connect busway to other Siemens equipment, such as switchgear and switchboards. Sentron busway stubs can be shipped installed in Siemens switchboards and switchgear. This eliminates the field labor required to connect the busway to the switchboard, saving the installer time and money.

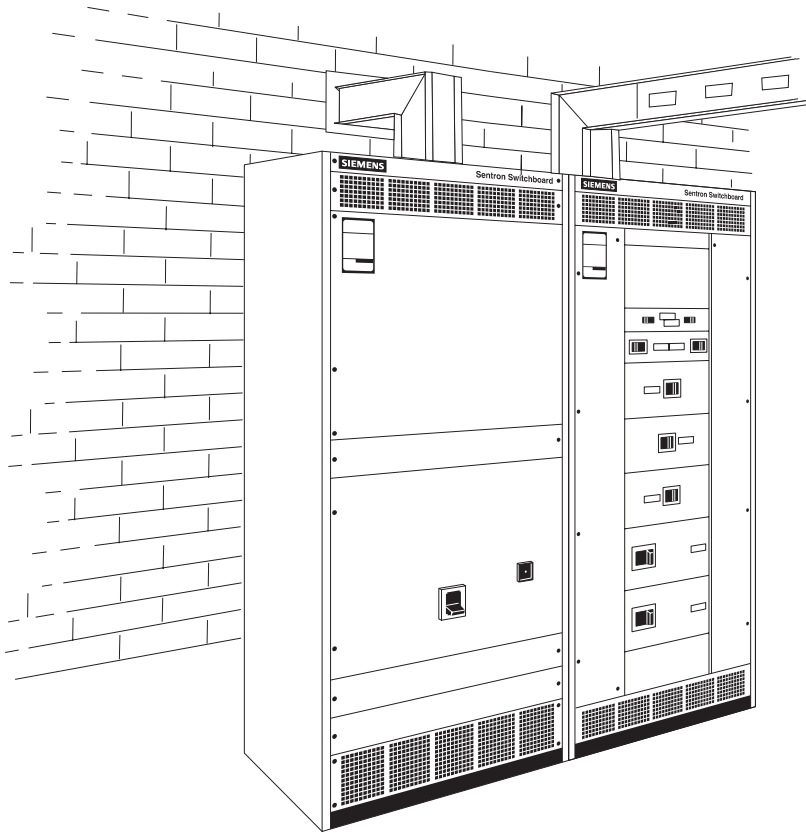

Flanged Ends

Flanged ends are also used to connect busway equipment such as switchgear and switchboards. These can be used with existing equipment. Siemens will furnish the outline drawings of this flanged end to the coordinating switchboard or equipment installer.

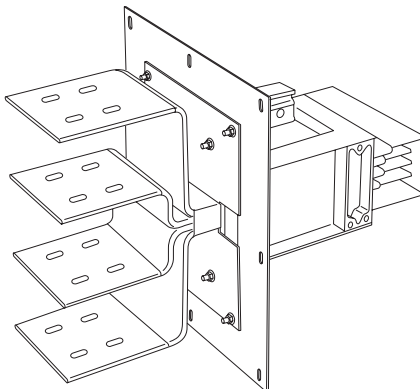

Service Heads

Service heads are used to connect the busway to the electric service. There are two types in the Sentron series. A single service head that has all three phases, or three separate heads, one for each phase.

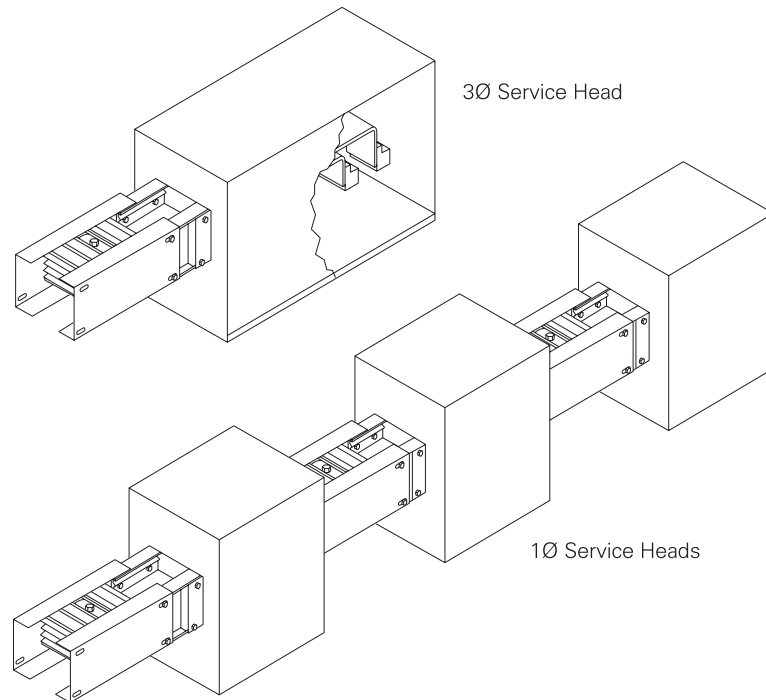

Riser Adaptors

In busway, a riser is a length of vertical busway. Panelboards and meter centers can be mounted directly to risers with a side-mounted adapter. When Sentron plug-in busway is used as a riser, plug-in receptacles are located only on one side.

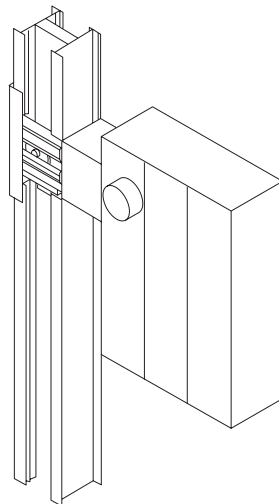

Side Mounted Adaptor

Phase Rotation

Some applications may require a phase rotation of the power supply to be reversed. The direction of rotation of a 3Ø AC motor, for example, is determined by the phase sequence of the power supply.

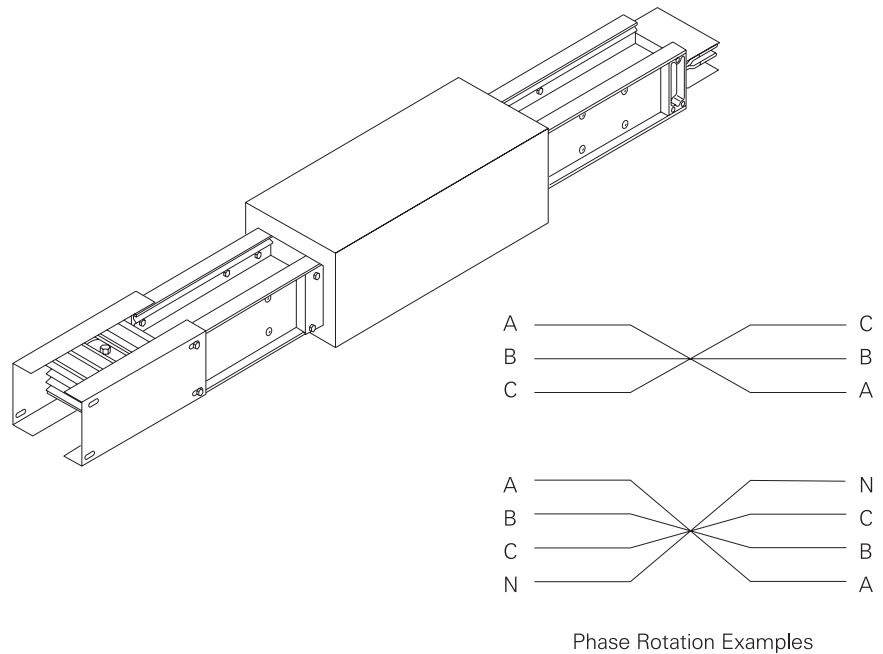

Reducers

A busway reducer is used to reduce the allowable ampere rating. Money can often be saved by using a lower rated group of sections near the end of a busway run. A branch circuit, for example, does not need as high an ampere rating as the main feeder circuit.

Article 368.11 of the *NEC*[®] states that *overcurrent protection shall be required where busways are reduced in ampacity.*

There is an exception to this article.

Exception: For industrial establishments only, omission of overcurrent protection shall be permitted at points where busways are reduced in ampacity, provided that the length of the busway having the smaller ampacity does not exceed 15 m (50 ft) and has an ampacity at least equal to one-third the rating or setting of the overcurrent device next back on the line, and provided further that such busway is free from contact with combustible material.

NEC[®] and *National Electrical Code*[®] are registered trademarks of the National Fire Protection Association. Reprinted with permission from NFPA 70-2002, the *National Electrical Code*[®], Copyright© 2001, National Fire Protection Association, Quincy, MA 02269.

Sentron busway offers fused reducers to meet the requirement of *NEC*[®] Article 368.11, and non-fused reducers when the exception is allowed. Illustrated below is a fused reducer.

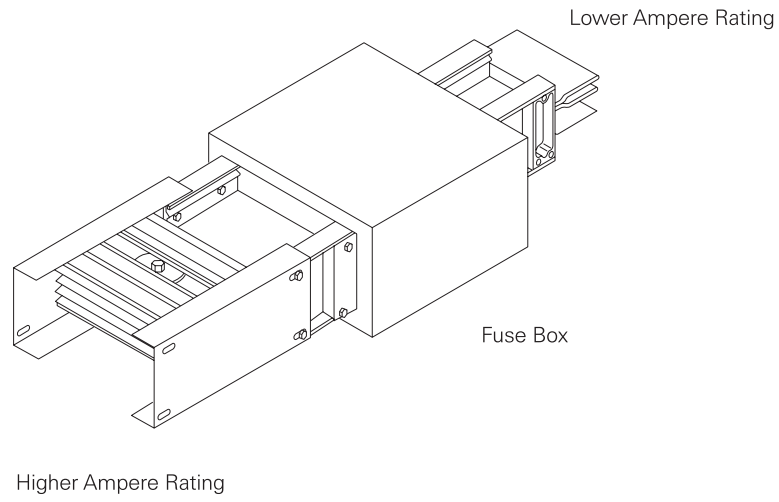

Expansion Fittings

Expansion fittings are used when a busway system crosses an expansion joint in a building, or on long straight runs where both ends are held in a permanent fixed position. The Sentron expansion fitting contains a sliding expansion enclosure. Flexible connectors in the expansion enclosure allow a ± 2 " movement.

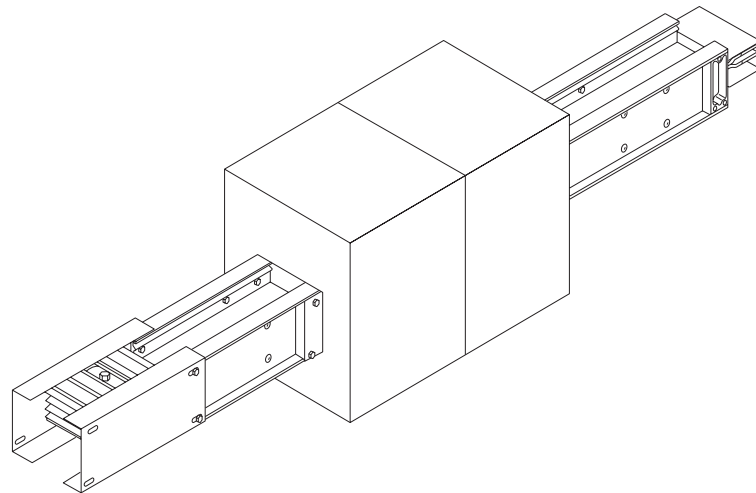

NEC[®] and *National Electrical Code*[®] are registered trademarks of the National Fire Protection Association.

Bus Plugs

Sentron II busway bus plugs are available with Siemens Sentron molded case circuit breakers or Siemens fusible switch.

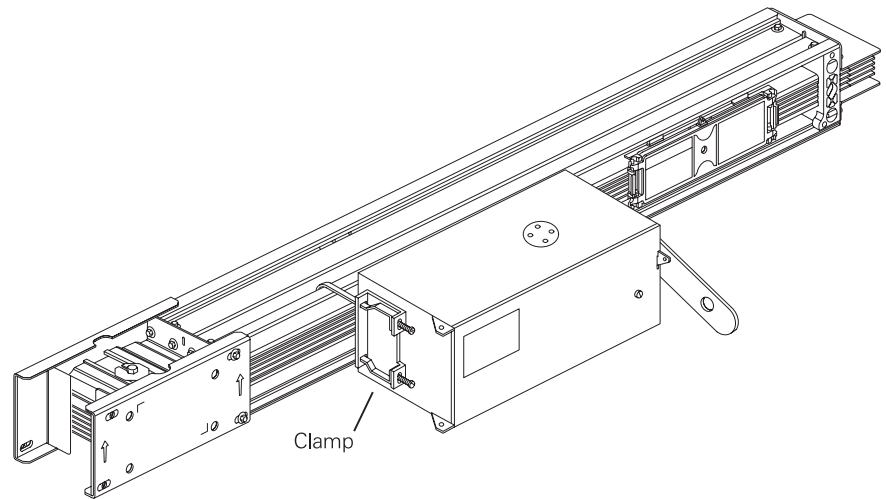

Sentron II bus plugs feature a visible position indicator and relocateable operating handle. Alignment and interlock tabs prevent the plug from being installed 180° out of position and ensures that the plug is in the off position during installation and removal. Clamp assemblies are used to draw the bus plug firmly against the busway housing. Sentron Bus Plugs are designed with standard wire bending space and extended wire bending space (gutter). Plug-in units can be mounted horizontally or vertically (riser).

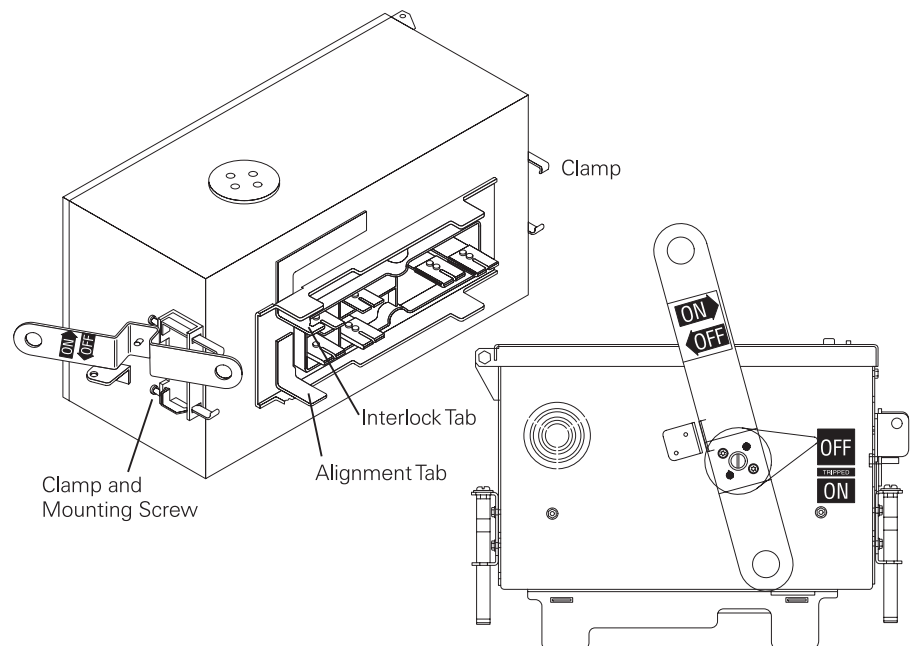

In-line Disconnect Cubicle

Cubicles provide a means of mounting switches or circuit breakers where power enters or leaves a busway system. In-line disconnect cubicles are used where bolted connections are preferred, or at ampere ratings exceeding the standard plug-in unit ratings.

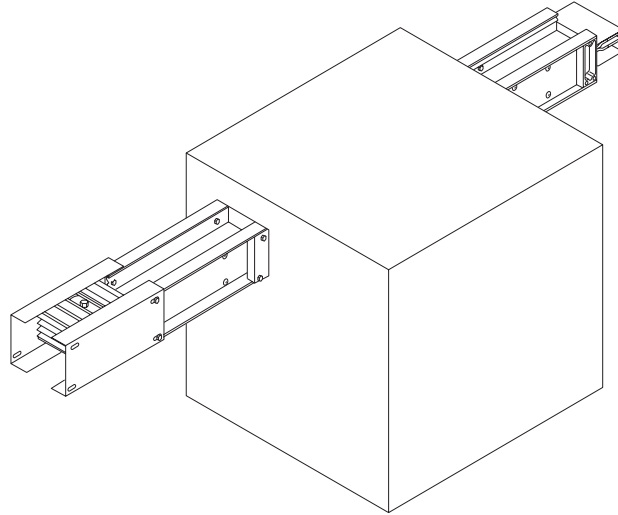

End Closer

End closers are used to safely terminate a run of busway and protect the bus bar ends.

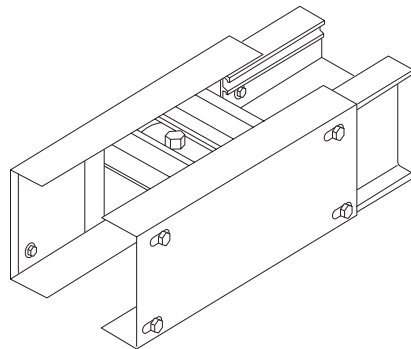

Hangers

Various hangers are used to support busway. When a vertical run of busway passes through a floor, a floor support is required. Spring hangers provide secure mounting of Sentron busway in riser applications. These hangers counter the weight of the busway on each floor and compensate for minimal building movement and thermal expansion.

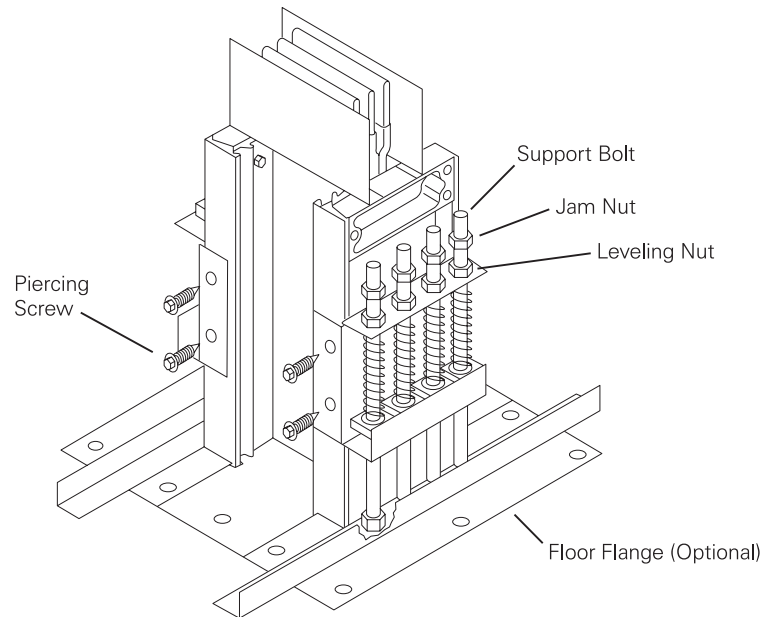

Several types of hangers are available to suspend the busway from the ceiling, structural steel support, or mounted to a wall.

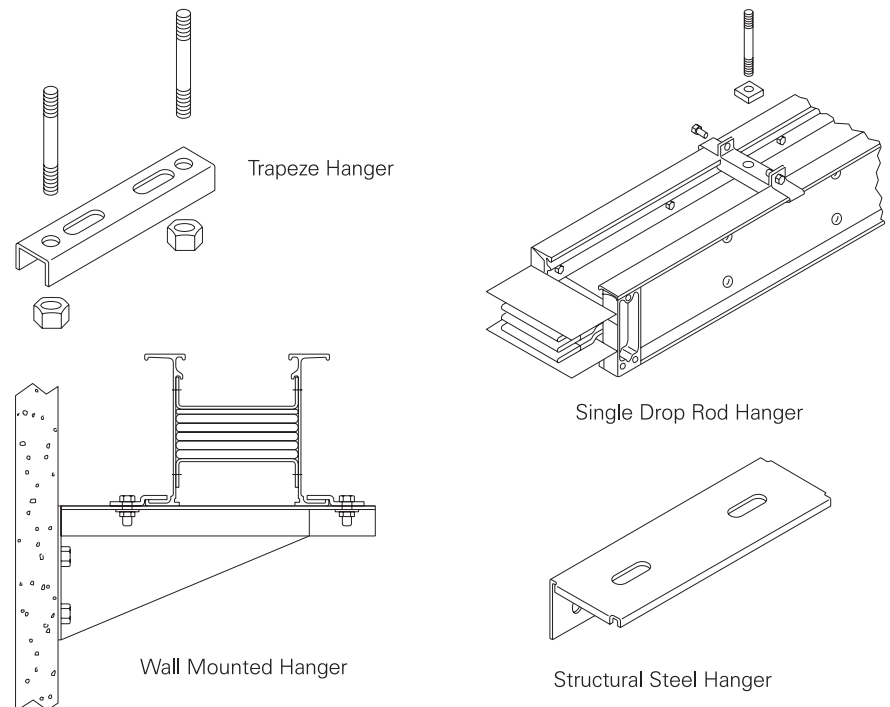

Flanges

Wall, ceiling, and floor flanges are designed to close off the area around the busway as it passes through a wall, ceiling, or floor. The flange does not provide an air tight seal around the busway.

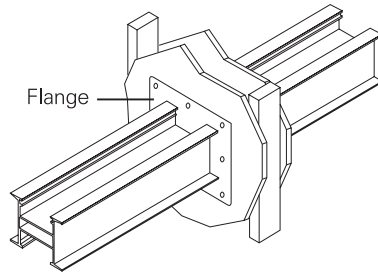

Roof flanges provide a watertight seal when outdoor rated busway enters through a roof. The pitch or angle of the roof must be specified when ordering roof flanges.

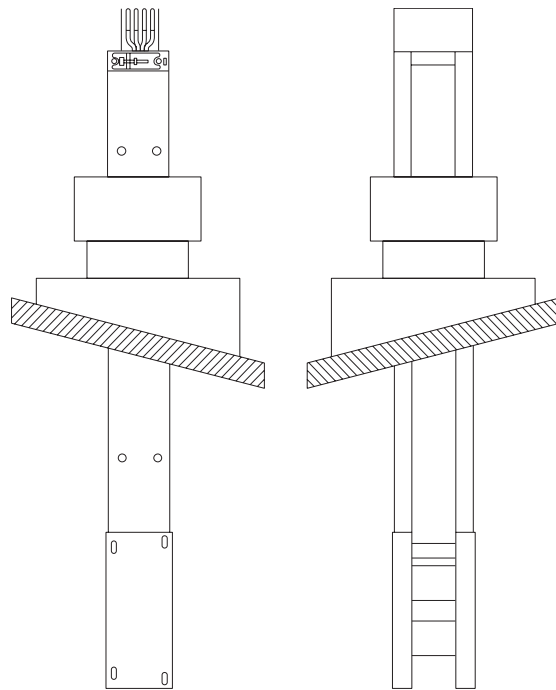

Review 4

Identify the components in the following illustration:

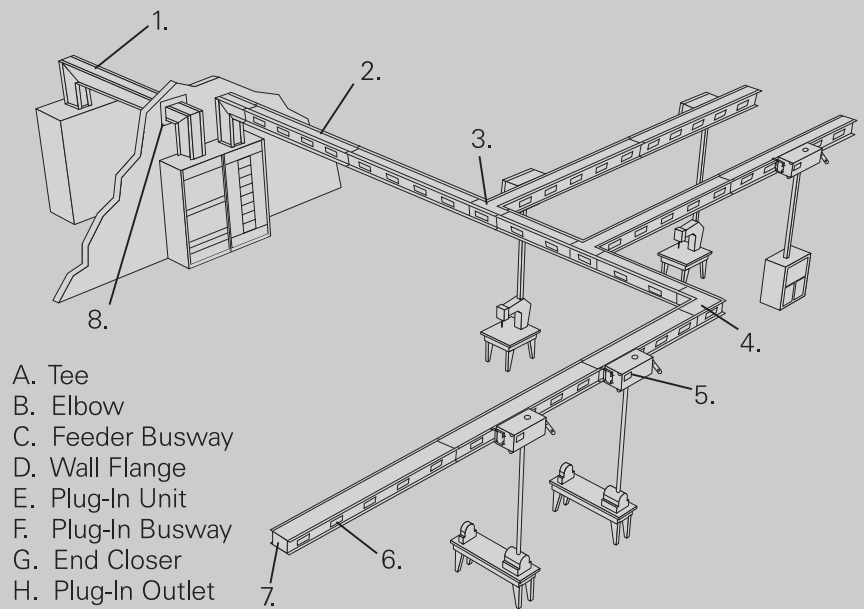

1. _____

2. _____

3. _____

4. _____

5. _____

6. _____

7. _____

8. _____